



HS-100

USB Audio Single Chip

DESCRIPTION

HS-100 is a new highly-integrated, low-power consumption USB audio single chip solution optimized typically for USB headset, headphone, and dongle applications. All necessary analog and digital modules are embedded in HS-100, including stereo DAC and earphone driver, mono ADC, microphone pre-amp booster, PLL, regulator, and USB transceiver. Many features of HS-100 are programmable with jumper pins or external EEPROM. Customers can customize unique USB VID / PID / Product_String / Manufacture_String and initial volume settings via an external EEPROM. In addition, HS-100 supports HID compliant volume control pins such as Playback Mute, Volume Up/Down, plus a Record Mute pin. HS-100 also offers playback operation and record mute LED indicator control pins to fulfill a better user experience and cost-effective product.

BLOCK DIAGRAM

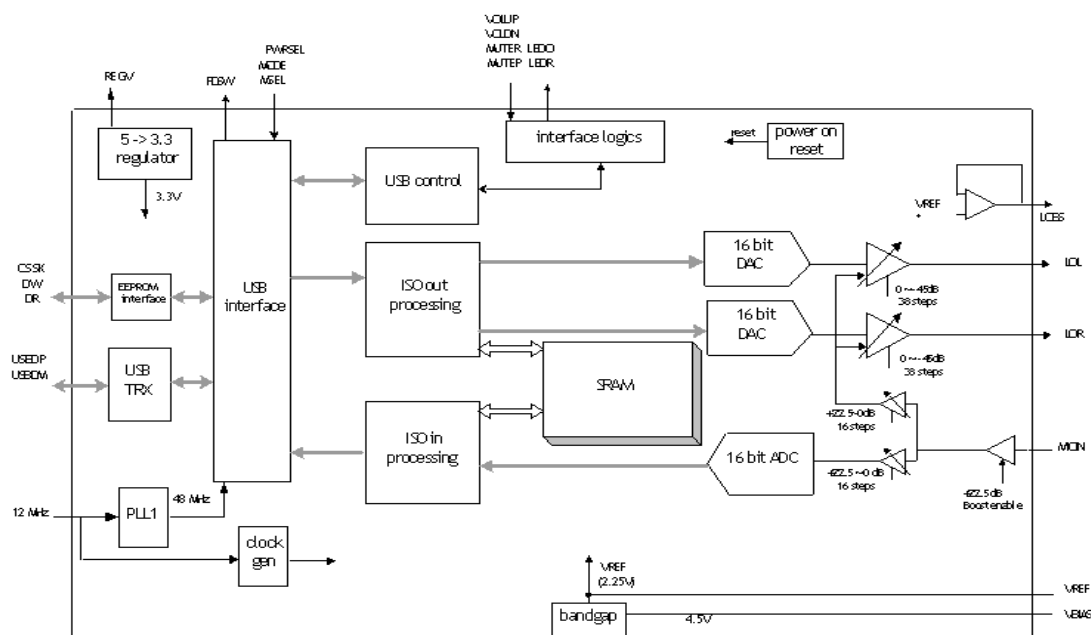

FEATURES

- Compliant with USB 2.0 Full-Speed operation
- Compliant with USB Audio Device class specification v1.0
- Supports USB Suspend/Resume Mode and remote wakeup with volume control pins
- Single 12MHz crystal input with on-chip PLL and embedded USB transceiver
- Jumper pin for Headset Mode (Playback + Recording) or Speaker/Headphone Mode (Playback Only)
- Jumper pin for Mixer Unit enable/disable under Headset Mode
- Jumper pin for Power Mode setting
- In Headset Mode, USB audio function topology has 2 Input Terminals, 2 Output Terminals, 1 Mixer Unit, 1 Selector Unit, and 3 Feature Units
- In Speaker Mode, USB audio function topology has 1 Input Terminal, 1 Output Terminal, and 1 Feature Unit.



HS-100

USB Audio Single Chip

TABLE OF CONTENTS

Release Note	3
1. Description and Overview	4
2. Features	4
3. Pin Descriptions	6
3.1 Pin Assignment.....	6
3.2 Pin-Out Diagram.....	6
3.3 Pin Description.....	7
4. Block Diagram	9
5. Function Descriptions	10
5.1 USB Interface	10
5.1.1 Device Descriptor	10
5.1.2 Configuration Descriptor	11
5.1.3 Content Format for 93C46.....	12
5.1.4 USB Audio Topology Diagram	13
5.2 Jumper Pins and Mode Setting:.....	13
5.3 HID Feature and Descriptions	14
5.3.1 HID Descriptor	15
5.3.2 Windows Software Architecture for HID	16
6. Electrical Characteristics	17
6.1 Absolute Maximum Rating	17
6.2 Operation Conditions	17
6.3 Analog Performance	18
7. Ordering Information	19



HS-100

USB Audio Single Chip

Release Note

Revision	Date	Description
0.9	21 Sep 2009	First release of the datasheet
1.0	05 Nov 2009	Official Release
1.1	30 Dec 2009	Pin-35 name correction



HS-100

USB Audio Single Chip

1. Description and Overview

HS-100 is a new highly-integrated, low-power consumption USB audio single chip solution optimized typically for USB headset, headphone, and dongle applications. All necessary analog and digital modules are embedded in HS-100, including stereo DAC and earphone driver, mono ADC, microphone pre-amp booster, PLL, regulator, and USB transceiver. Many features of HS-100 are programmable with jumper pins or external EEPROM. Customers can customize unique USB VID / PID / Product_String / Manufacture_String and initial volume settings via an external EEPROM.

In addition, HS-100 supports HID compliant volume control pins such as Playback Mute, Volume Up/Down, plus a Record Mute pin. HS-100 also offers playback operation and record mute LED indicator control pins to fulfill a better user experience and cost-effective product. With the world's leading Cmedia USB audio solution, customers can easily and quickly bring the quality USB headset peripherals to the market.

2. Features

- Compliant with USB 2.0 Full-Speed operation
- Compliant with USB Audio Device class specification v1.0
- Supports USB Suspend/Resume Mode and remote wakeup with volume control pins
- Single 12MHz crystal input with on-chip PLL and embedded USB transceiver
- Jumper pin for Headset Mode (Playback + Recording) or Speaker/Headphone Mode (Playback Only)
- Jumper pin for Mixer Unit enable/disable under Headset Mode
- Jumper pin for Power Mode setting
- In Headset Mode, USB audio function topology has 2 Input Terminals, 2 Output Terminals, 1 Mixer Unit, 1 Selector Unit, and 3 Feature Units
- In Speaker Mode, USB audio function topology has 1 Input Terminal, 1 Output Terminal, and 1 Feature Unit.
- Support one control endpoint, one Isochronous out endpoint, one Isochronous in endpoint, and one Interrupt in endpoint
- Alternate zero bandwidth setting for releasing playback bandwidth on USB bus when this device is inactive
- Volume up, volume down, and playback mute support USB HID for PC host system SW volume synchronization
- Record Mute pin with a LED Indicator for record mute status
- External EEPROM interface for vendor Specific USB VID, PID, Product String, Manufacture String, and Serial Number
- Isochronous transfer uses Adaptive Mode with internal PLL for synchronization



HS-100

USB Audio Single Chip

- 48K/44.1KHz sampling rate for both playback and recording
- Soft Mute function
- Embedded high performance 16bit audio DAC with earphone phone buffer
- Embedded 16bit ADC input with Microphone Boost
- Embedded power on reset block
- Embedded 5V to 3.3V regulator for single external 5V power
- Compatible with Win98 SE / Win ME / Win 2000 / Win XP / Win Vista / Win 7 / Mac OS X / Linux without additional driver
- Industrial standard 48-pin LQFP Package

HS-100

USB Audio Single Chip



3. Pin Descriptions

3.1 Pin Assignment

Pin #	Signal Name	Pin #	Signal Name	Pin #	Signal Name	Pin #	Signal Name
1	DW	13	N.C.	25	DVSS	37	N.C.
2	DR	14	N.C.	26	VBIAS	38	N.C.
3	SK	15	N.C.	27	VREF	39	REGV
4	CS	16	N.C.	28	MICIN	40	MSEL
5	MUTER	17	MUTEP	29	AVDD	41	VOLUP
6	PWRSEL	18	N.C.	30	LOL	42	PDSW
7	XI	19	LEDR	31	LOBS	43	USBDP
8	XO	20	TEST	32	LOR	44	USBDM
9	N.C.	21	N.C.	33	AVSS	45	N.C.
10	MODE	22	N.C.	34	AVDD	46	N.C.
11	LEDO	23	N.C.	35	DVDD	47	VOLDN
12	DVSS	24	N.C.	36	DVSS	48	N.C.

3.2 Pin-Out Diagram

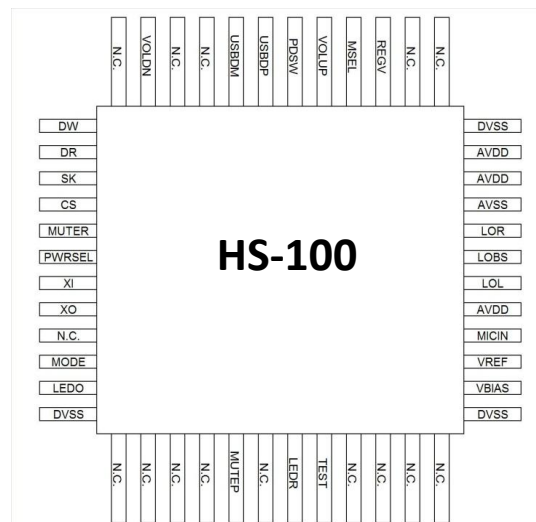



HS-100

USB Audio Single Chip

3.3 Pin Description

Pin #	Symbol	Type	Description
1	DW	DIO, 8mA, PD, 5VT	USB Controller Data Read From EEPROM Interface. EEPROM Data Output.
2	DR	DO, 4mA, SR	USB Controller Data Writes to EEPROM Interface. EEPROM Data Input.
3	SK	DO, 4mA, SR	EEPROM Interface Clock (100KHz)
4	CS	DO, 4mA, SR	EEPROM Interface Chip Select
5	MUTER	DI, ST, PU	Mute Recording (Edge Trigger with de-Bouncing)
6	PWRSEL	DI, ST	H: Pull Up to 3.3V; L: Pull Down to Ground Speaker Mode H : Self Power with 100mA ; L : Bus Power with 500mA Headset Mode H : Bus Power with 100mA ; L : Bus Power with 500mA
7	XI	DI	Input Pin for 12MHz Oscillator
8	XO	DO	Output Pin for 12MHz Oscillator
10	MODE	DI, ST	H: Pull Up to 3.3V; L: Pull Down to Ground L : Headset Mode: Playback & Recording H : Speaker Mode: Playback Only
11	LEDO	DO, SR, 8mA	LED for Operation; Output H for Power On; Toggling for Data Transmit
12	DVSS	P	Digital Grounding
17	MUTEP	DI, ST, PU	Mute Playback (Edge Trigger with de-Bouncing)
19	LEDR	DO, SR, 8mA	LED for Mute Recording Indicator; Output H when Recording is Muted
20	TEST	DI, ST, PD	Test Mode Select Pin; Pull Low for Normal Operation
25	DVSS	P	Digital Ground
26	VBIAS	AO	Microphone Bias Voltage Supply (4.5V)
27	VREF	AO	Connecting to External Decoupling Capacitor for Embedded Bandgap Circuit; 2.25V Output
28	MICIN	AI	Microphone Input
29	AVDD	P	5V Analog Power for Analog Circuit
30	LOL	AO	Line Out Left Channel (Headphone Out Left)
31	LOBS	AO	DC 2.25V Output for Line Out Bias (Headphone Out Bias) as a capless ground
32	LOR	AO	Line Out Right Channel (Headphone Out Right)
33	AVSS	P	Analog Ground



HS-100

USB Audio Single Chip

34	AVDD	P	5V Analog Power for Analog Circuit
35	DVDD	P	5V Digital Power for Digital Regulator Circuit
36	DVSS	P	Digital Grounding
39	REGV	AO	3.3V Reference Output for Internal 5V-to-3.3V Regulator
40	MSEL	DI, ST	Mixer Enable/Disable pin H: Pull Up to 3.3V, L: Pull Down to Ground L: Without Mixer; H: With Mixer (With Default Mute) USB Descriptors are changed accordingly
41	VOLUP	DI, ST, PU	Volume Up (Edge Trigger with de-Bouncing)
42	PDSW	DO, 4mA, OD	Power Down Switch Control (for PMOS Polarity) 0: Normal Mode, 1: Power Down Mode
43	USBDP	AIO	USB Data D+
44	USBDM	AIO	USB Data D-
47	VOLDN	DI, ST, PU	Volume Down (Edge Trigger with de-Bouncing)
13-15, 18, 21-24, 37, 38, 45, 46, 48	NC	--	No functions

Note: DI - Digital Input Pad, DO - Digital Output Pad, DIO - Digital bi-Directional Pad, AI/AO/AIO - Analog Pad, SR Slew Rate Control, ST - Schmitt Trigger, PD/PU - Pull Down or Pull Up, 5VT - 5-Volt Tolerant (3.3V Pad), OD - Open Drain



HS-100

USB Audio Single Chip

4. Block Diagram

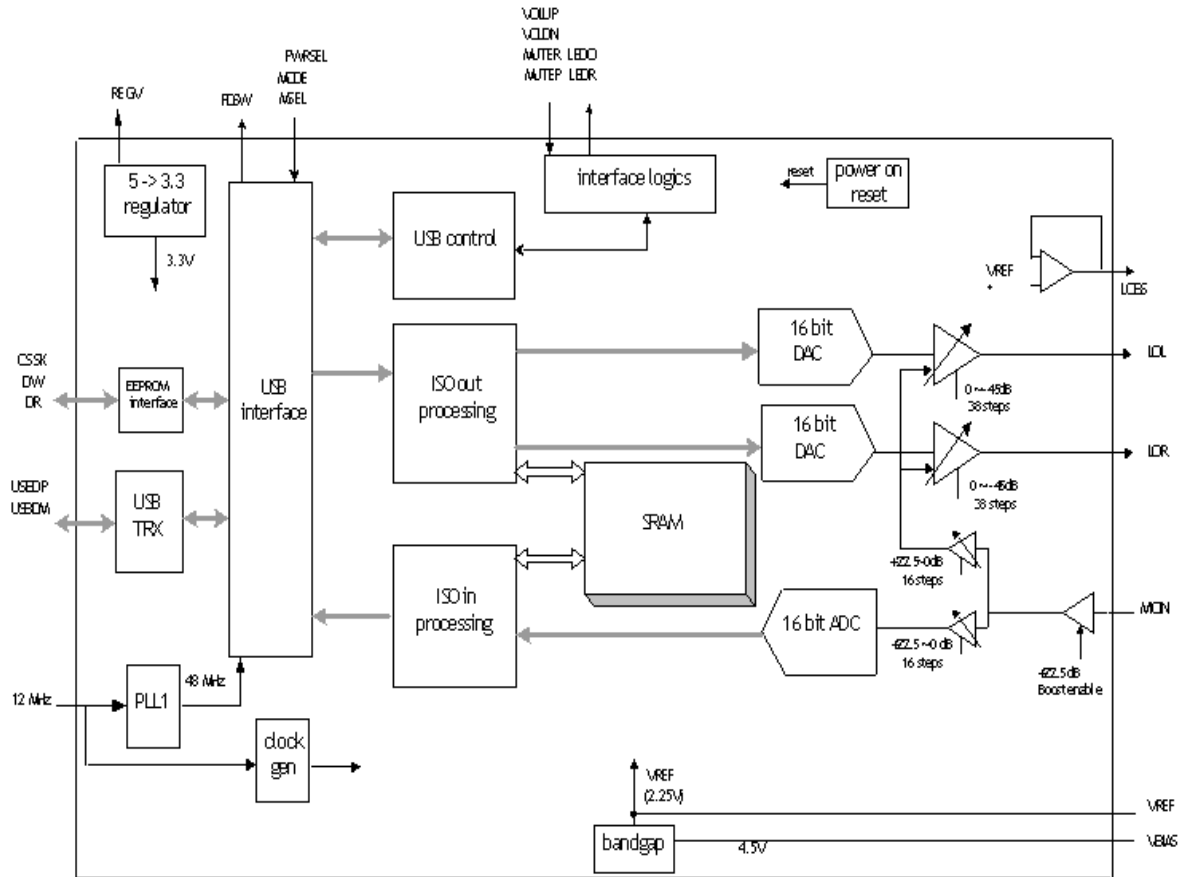

Block Diagram Of HS-100



HS-100

USB Audio Single Chip

5. Function Descriptions

5.1 USB Interface

HS-100 integrates USB transceiver, PLL, and regulator so only a few passive components are necessary for the USB interface connection. Default USB descriptors are embedded in HS-100; therefore no additional design effort is needed for a generic USB operation. For customized product, customer can attach a 93C46 EEPROM to override the embedded VID, PID and provide addition serial number for each set. HS-100 automatically detects 93C46 existence and performs the overwrite function during power up.

5.1.1 Device Descriptor

Offset	Field	Size	Value (Hex)	Description
0	bLength	1	12	Total 18 Bytes
1	bDescriptorType	1	01	Device Descriptor
2	bcdUSB	2	0110	USB 1.1 compliant.
4	bDeviceClass	1	00	
5	bDeviceSubClass	1	00	
6	bDeviceProtocol	1	00	
7	bMaxPacketSize0	1	40	Endpoint zero Size = 64 bytes
8	idVendor	2	0d8c	Vendor ID
10	idProduct	2	013C	Product ID Programmable by MSEL and MODE pin
12	bcdDevice	2	0100	Device compliant to the Audio Device Class specification version 1.00
14	iManufacturer	1	01	Index of string descriptor describing manufacturer
15	iProduct	1	02	Index of string descriptor describing product
16	iSerialNumber	1	03	Index of string descriptor describing the device's serial number
17	bNumConfigurations	1	01	Configurations number = 1

Note: VID, PID, and serial number can be overridden by external EEPROM content



HS-100

USB Audio Single Chip

5.1.2 Configuration Descriptor

Offset	Field	Size	Value (Hex)	Description
0	bLength	1	09	Total 9 Bytes
1	bDescriptorType	1	02	Configuration Descriptor
2	wTotalLength	2		Total length of data returned for this configuration Programmable by MSEL and MODE pin
4	bNumInterfaces	1	04 or 03	Number of interfaces supported by this Configuration (Decided by Speaker Mode and Head Set mode): 0: control interface 1: ISO-OUT interface 2: ISO-IN interface (Option) 3: INT-IN(HID) interface
5	bConfigurationValue	1	01	
6	iConfiguration	1	00	
7	bmAttributes	1	A0 or E0	Programmable by PWRSEL
8	bMaxPower	2	32 or FA	Maximum power consumption of the USB Programmable by MODE and PWRSEL



HS-100

USB Audio Single Chip

5.1.3 Content Format for 93C46

Addr (Dec)	Addr (Hex)	Description	
0	0x00	Magic Word 0x670X where X = bit 4, 3, 2, 1 bit 3 The value within address 0x2A,0x2B is valid 1: valid 0: invalid bit 2 manufacture string enable 1: enable(default) 0: disable bit 1 serial number enable control 1: enable 0: disable(default) bit 0 product string enable control 1: enable(default) 0: disable	
1	0x01	VID 2-byte	
2	0x02	PID 2-byte	
3	0x03	Serial number length (low byte)	Serial number 1 st byte (high byte)
4 ~ 9	0x04 ~ 0x09	Serial number 12-byte	
10	0x0A	Product string length (low byte)	Product string 1 st byte (high byte)
11 ~ 25	0x0B ~ 0x19	Product string 30-byte (default: USB PnP Sound Device)	
26	0x1A	Manufacture string length (low byte)	Manufacture string 1 st (high byte)
27 ~ 41	0x1B ~ 0x29	Manufacture string 30-byte (default: C-Media Electronics Inc.)	
42	0x2A	bit 15 - 9 DAC initial volume (7-bit) max:0x02 min:0x4a bit 8 <reserved> bit 7 - 3 ADC initial volume (5-bit) max: 0x08 min:0x78 bit 2 - 0 <reserved>	
43	0x2B	bit 15 - bit9 <reserved> bit 8 Shutdown DAC analog 1:shutdown 0:active(default) bit 7 Total Power Control 1:enable 0:disable(default) bit 6 Reserved, should be 0 bit 5 MIC High Pass Filter 1:enable(default) 0:disable bit 4 ADC synchronization mode 1:enable 0:disable(default) bit 3 MIC BOOST 1:enable(default) 0:disable bit 2 DAC Output Terminal property set to SPK or HP 1: Headset 0: Speaker(default) bit 1 HID 1: enable (default) 0: disable bit 0 Remote Wakeup enable/disable 1: enable 0: disable(default)	
44 ~ END	0x2C ~ END	<reserved>	

HS-100

USB Audio Single Chip

5.1.4 USB Audio Topology Diagram

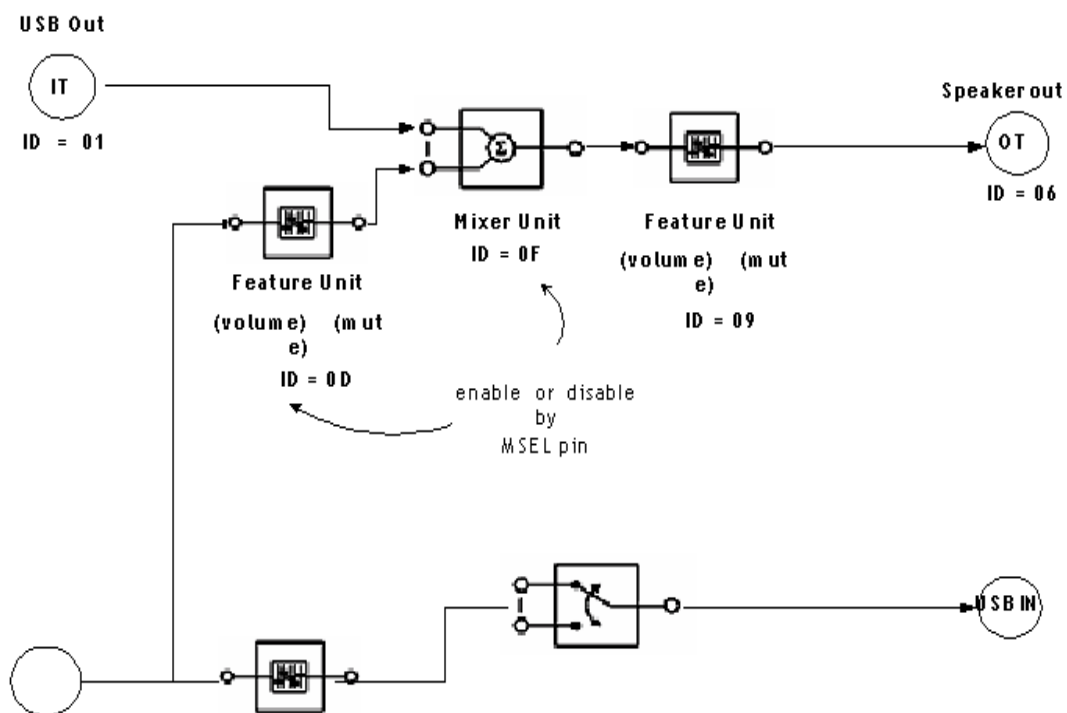

USB Audio Topology Diagram

5.2 Jumper Pins and Mode Setting:

Several jumper pins can set the configuration of HS-100. These jumper pin settings affect both USB descriptors and USB audio topology. If MODE pin is pulled up to 3.3V (speaker mode), a playback only function is activated and there is no recording function declared to the host. At this setting, MSEL pin is ignored and only one input terminal, one output terminal and one feature unit is declared in USB audio topology.

If MODE pin is pulled low (headset mode), a full duplex playback and recording function is reported to the host. MSEL pin setting activates one mixer unit and one feature unit. The following USB audio topology in Chapter: 7.1.4 is an example of headset mode. PWRSEL pin affects the power configuration of HS-100; together with MODE pin totally 4 combinations are programmable.



HS-100

USB Audio Single Chip

Combinations		MODE	
		3.3V	GND
PWRSEL	3.3V	Speaker Mode : Playback Only (Self Power with 100mA)	Headset Mode : Playback + Recording (Bus Power with 100mA)
	GND	Speaker Mode : Playback Only (Bus Power with 500mA)	Headset Mode : Playback + Recording (Bus Power with 500mA)

VSEL jumper pin sets the output voltage swing. When VSEL is connected to 5V, output voltage swing is 3.5Vpp; when VSEL is connected to ground, output voltage is 2.5Vpp.

5.3 HID Feature and Descriptions

HID feature is provided by HS-100 so user setting to volume up, volume down, and playback mute button pin is reported to the host to synchronize host side setting. In addition, all HS-100 internal registers can be accessed via HID function call.

USB protocols can configure devices at startup or when they are plugged in at run time. These devices are broken into various device classes. Each device class defines the common behavior and protocols for devices that serve similar functions. The HID (Human Interface Device) class is one of the device classes.

The HID class consists primarily of devices that are used by humans to control the operation of computer systems. Typical examples of HID class devices include:

- Keyboards and pointing devices, for example: mouse, trackballs, and joysticks.
- Front-panel controls, for example: knobs, switches, buttons, and sliders.
- Controls that might be found on devices such as VCR remote controls, games or simulation devices, for example: data gloves, throttles, and steering wheels.
- Devices that may not require human interaction but provide data in a similar format to HID class devices, for example: bar-code readers, thermometers, or voltmeters.



HS-100

USB Audio Single Chip

5.3.1 HID Descriptor

HID Interface Descriptor

Offset	Field	Size	Value (Hex)	Description
0	bLength	1	09	Size of this descriptor: 9 byte
1	bDescriptorType	1	04	INTERFACE descriptor type
2	bInterfaceNumber	1	03	Number of Interface: 3
3	bAlternateSetting	1	00	alternate 0
4	bNumEndpoints	1	01	Number of endpoints used by this Interface: 1
5	bInterfaceClass	1	03	HID Interface Class
6	bInterfaceSubClass	1	00	No Subclass
7	bInterfaceProtocol	1	00	Must be set to 0
8	iInterface	1	00	Index of a string descriptor that describes this interface.

HID Descriptor

Offset	Field	Size	Value (Hex)	Description
0	bLength	1	09	Total 9 Bytes
1	bDescriptorType	1	21	HID Descriptor Type
2	bcdHID	2	0100	HID class version 1.00
4	bCountryCode	1	00	
5	bNumDescriptors	1	01	
6	bDescriptorType	1	22	Report Descriptor
7	wDescriptorLength	2	0030	Numeric expression that is the total size of the optional descriptor: 48 Bytes

Interrupt In Endpoint Descriptor

Offset	Field	Size	Value (Hex)	Description
0	bLength	1	07	Total 7 Bytes
1	bDescriptorType	1	05	ENDPOINT Descriptor Type
2	bEndpointAddress	1	83	IN Endpoint Endpoint number = 3
3	bmAttributes	1	03	Interrupt endpoint type
4	wMaxPacketSize	2	0004	Maximum packet size: 4 bytes
6	bInterval	1	20	2ms



HS-100

USB Audio Single Chip

5.3.2 Windows Software Architecture for HID

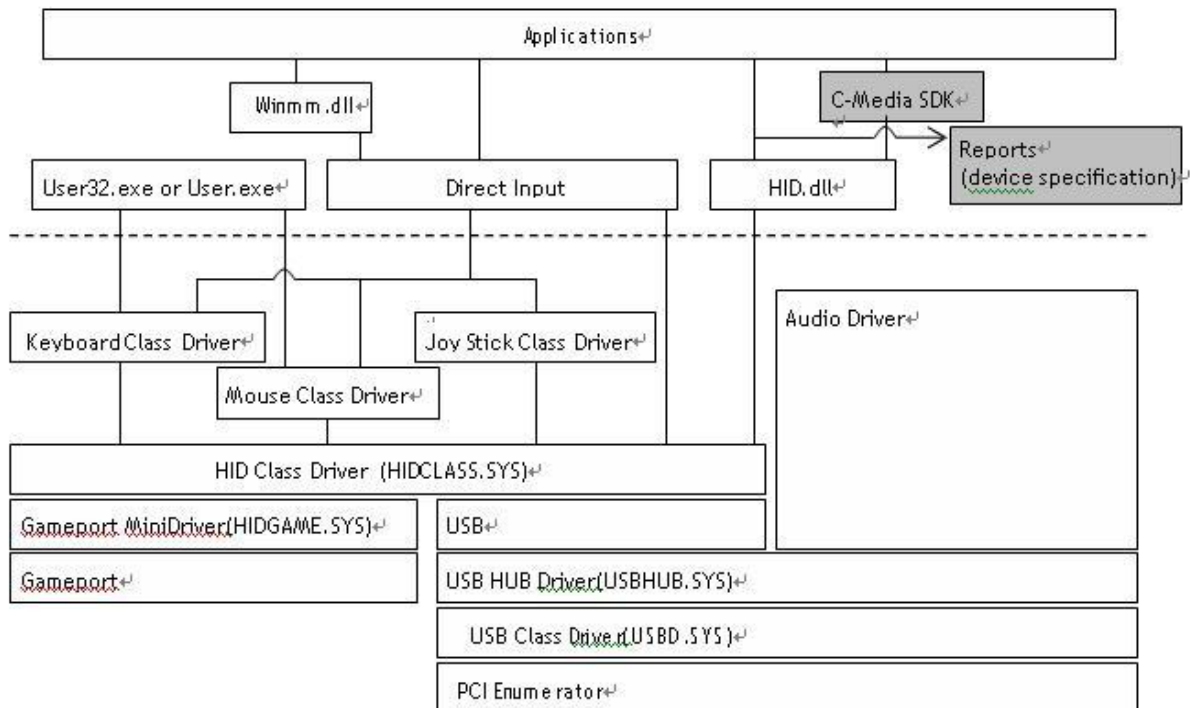

Note: Please contact with our sales for the C-Media SDK example if needed.



HS-100

USB Audio Single Chip

6. Electrical Characteristics

6.1 Absolute Maximum Rating

Symbol	Parameter	Value	Unit
Dvmin	Min Digital Supply Voltage	- 0.3	V
Dvmax	Max Digital Supply Voltage	+ 6	V
Avmin	Min Analog Supply Voltage	- 0.3	V
Avmax	Max Analog Supply Voltage	+ 6	V
Dvinout	Voltage on any Digital Input or Output Pin	-0.3 to +5.5	V
Avinout	Voltage on any Analog Input or Output Pin	-0.3 to +5.5	V
T_{stg}	Storage Temperature Range	-40 to +125	°C
ESD (HBM)	ESD Human Body Mode	4000	V
ESD (MM)	ESD Machine Mode	200	V
Latch Up	JEDEC Standard No.78, Mar 1997	200	mA

6.2 Operation Conditions

Operation conditions				
	Min	Typ	Max	Unit
Analog Supply Voltage	4.5	5.0	5.5	V
Digital Supply Voltage	4.5	5.0	5.5	V
Total Power Consumption	-	40		mA
Suspend Mode Power Consumption	-	500		uA
Operating ambient temperature	-15	-	70	°C



HS-100

USB Audio Single Chip

6.3 Analog Performance

	Min	Typ	Max	Unit
DAC (10K Ohm Loading)				
Resolution	-	16	-	Bits
THD + N (-3dBr)	-	-72	-	dB
SNR	-	93	-	dB
Dynamic range	-	93	-	dB
Frequency response 48KHz	20	-	20K	Hz
Frequency Response 44.1KHz	20	-	20K	Hz
Output Voltage (rms)	-	1.25	-	Vrms
Output Voltage Swing	0.5	-	4.0	V
DAC (32 Ohm Loading)				
Resolution	-	16	-	Bits
THD + N (-3dBr)	-	-70	-	dB
SNR	-	93	-	dB
Dynamic Range	-	93	-	dB
Frequency Response 48KHz	20	-	20K	Hz
Frequency Response 44.1KHz	20	-	20K	Hz
Output Voltage (rms)	-	1.20	-	Vrms
Output Voltage Swing	0.5	-	4.0	V
ADC				
Resolution	-	16	-	bit
THD + N (-3dBr)	-	-76	-	dB
SNR	-	83	-	dB
Dynamic Range	-	81	-	dB
Frequency Response 48KHz	20	-	19.2K	Hz
Frequency Response 44.1KHz	20	-	17.6K	Hz
Input Range	0	-	2.88	Vpp
Amplification				
Volume Control Level	-45	-	0	dB
Volume Control Step	-	38	-	Steps
Microphone Input				
Boost Gain	-	+20	-	dB
Gain Adjustment Range	0	-	+22.5	dB
Gain Adjustment Steps	-	16	-	Steps
Mixer Gain Adjustment	-33.0	-	12.0	dB
Mixer Gain Adjustment Steps	-	32	-	Steps



HS-100

USB Audio Single Chip

7. Ordering Information

Model Number	Package	Operating Ambient Temperature	Supply Range
HS-100	48-Pin LQFP 7mm×7mm×1.4mm (Plastic)	0 °C to +70 °C	DVdd = 5V, AVdd = 5V

Outline Dimensions Dimensions shown in inches and (mm)

48 Pin - Low-profile Quad Flat Package (LQFP)

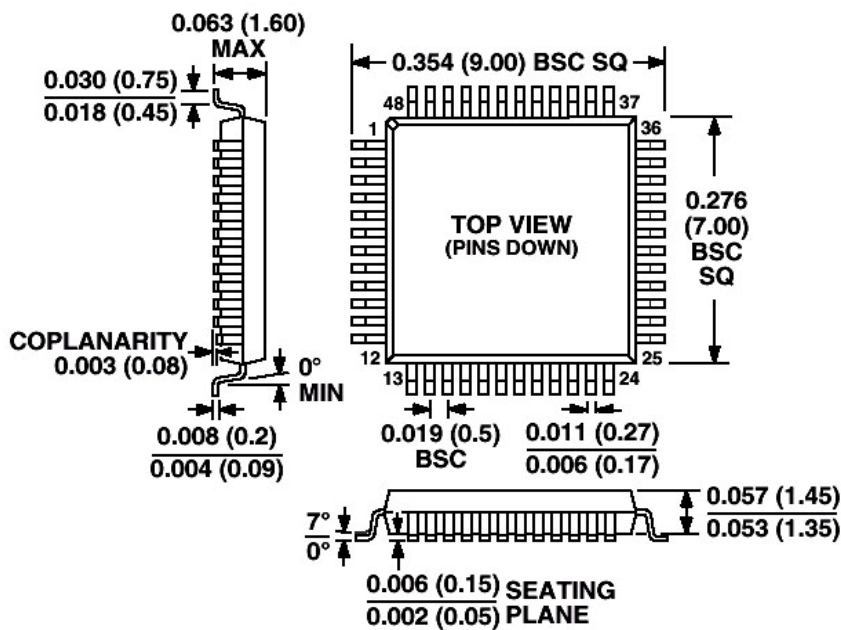

Ordering Information Of HS-100



HS-100

USB Audio Single Chip

— End of Specifications —

C-MEDIA ELECTRONICS INC.

6F., 100, Sec. 4, Civil Boulevard, Taipei, Taiwan 106 R.O.C.

TEL : +886-2-8773-1100

FAX : +886-2-8773-2211

E-MAIL : sales@cmedia.com.tw

Disclaimer:

Information furnished by C-Media Electronics Inc. is believed to be accurate and reliable. However, no responsibility is assumed by C-Media Electronics Inc. for its use, nor for any infringements of patents or other rights of third parties that may result from its use. Specifications subject to change without notice. No license is granted by implication or otherwise under any patent or patent rights of C-Media. Trademark and registered trademark are the property of their respective owners.

www.cmedia.com.tw